

CONTENTS

Introduction	3
Standards	4
Validity	5
Glass rebate	6
Rebate size	6
Use of sealants	9
Glazing block guidelines	10
Role of glazing blocks	10
Material of glazing blocks	11
Heavy units	12
Location of blocks, bridges	12
Blocking mistakes	13
Flat glass sheets	14
Blocking of windows with muntin bars	14
Blocking of sloped glazing	14
Shaped units	15
Bent glass	16
Glazing systems	18
Use of gaskets	20
Pressure	21
Vertical installation	22
General glazing technology Aluminium, plastic	22
Composite constructions	23
Wood windows	23
Location of the pressure equalization openings	23
Ventilation of the rebate	24
Repair glazing of windows	24
Pressure equalization	24

 General Glazing Guidelines

Additional measures	26
Rooms with high humidity	28
Sloped installation	31
Glass types	33
Glass thickness	34
Cavity	34
Glass inset	34
Angle of slope	35
Heat build-up	36
Stepped edges	36
Edge cover	37
Glass rebate	37
System appearance	38
Performance glass: additional requirements	39
IGUs with solar control glass	39
Acoustic control	39
Thermal insulation	40
Solar control glass	41
Sliding doors	42
Determination of glass thickness: structural basics	43
Loads	43
Addition Inotes	44
Storage	44
Thermal loads	45
Surface damage	46
Installation at extreme elevations	48
Other factors	48
Glass breakage	49
Replacement and later deliveries	50

Introduction

This Guideline for glazing does not cover general specialist knowledge for processing of glass units and cannot encompass all project-specific conditions. It covers the basics for individual requirements. It is possible to classify difficult and varying situation and to estimate their influences. Only knowledge of the individual product specific information will allow an optimum glass application.

This Guideline also provides application technical notes, which should help the designer and glazier to accommodate certain conditions, constructions, uses and installation.

Particular attention is drawn to glass thickness determination, which must be checked against each application and glass type and the resulting stresses.

Notes:

- *Compliance with this guideline is a requirement of our Warranty!*
- *Basically a clear rebate with pressure equalization is applicable.*

General Glazing Guidelines

Standards

Austrian Standard ÖNORM B 2227 Glazier operations is a general technical standard for glazing. This glazing guideline assumes that the requirements of this standard are complied with during installation.

Should glazing not be possible in accordance with this guideline, then concerns should be made known and factually supported.

The following standards are also applicable:

- „Sealing of glazing – Glass rebate“ ÖNORM B 3722 and – Glazing systems ÖNORM B 3724, as well as the classification of sealants and gaskets e.g. from the Institut für Fenstertechnik e.V. in Rosenheim
- Technical guidelines for glazing industry, from the Federal Guild of Glaziers, insofar as these do not conflict with current standards and our guidelines.
- Information bulletins from AMFT ARGE of metal window/door/opening/facade manufacturers, insofar as these do not conflict with our guideline
- Guidelines for applications of Aluminium windows and Aluminium facades, issued by AMFT (Work group for manufacturers of metal windows/doors/openings/facades), insofar as these do not conflict with our guideline
- ECKELT Handbook Tolerances to evaluate visual quality
- ÖNORM B 3724 – Sealing of glazing with sealants 07/1999 and following editions

 General Glazing Guidelines**Validity**

This guideline is generally valid but cannot deal with every individual case. It is necessary to check to see whether the actual installation situation is covered within the basics of this document. Differing glass combinations and unusual surrounding conditions can have an influence on the type of glazing.

The existing relevance can only be determined by the specialist at the location and be evaluated with reference to the general technical information given in this guideline. For this reason it is necessary to realize that not just any glass combination which can be manufactured can also be installed anywhere. The same applies to the glazing system as well as for the potential protective measures during construction (e.g. covering of glazing, soiling, and additional wind loads etc.) as well as storage and transportation.

General Glazing Guidelines

Glass rebate design

It is generally determined that multi-pane insulated units must be professionally installed and set with glazing blocks.

For their glazing it is necessary to have perimeter glazing bars. Glazing bars are normally located on the inside. In situations of high humidity (e.g. swimming baths) it is normal to put the glazing bars on the outside.

Rebate size

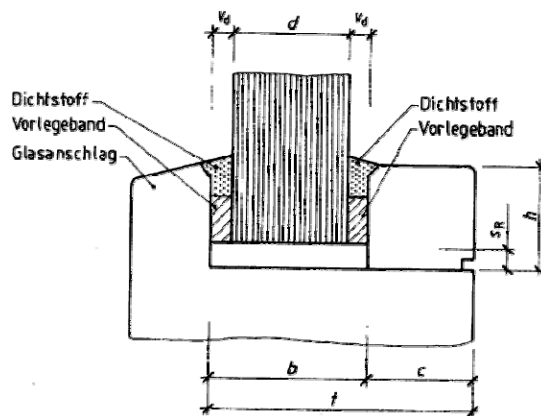

b – Rebate width = $v_d + d + v_d$
 v_d – Thickness of sealant tape 4.3.2
 d – Thickness of glass unit
 c – Width of glazing bar support
 t – Total rebate width
 h – Rebate height in accordance with 4.1.2
 s_R – clearance

Dimensioning of the rebate in accordance with ÖNORM B 3722
 Clause. 4.1.1 for monolithic glazing

- 12 mm up to a nominal thickness of 4 mm and a glass area of 1,50 m²
- 15 mm up to a nominal thickness of 4 mm to 6 mm and a glass area of 2,00 m²
- Above and beyond this the following formula is to be used:
- Basis value 11 mm + Nominal thickness (in mm) = Minimum rebate depth in mm

General Glazing Guidelines

Dimensioning of the rebate in accordance with ÖNORM B 3722 Clause. 4.1.2 for insulating glass

The rebate height „h“ depends on the longest edge of the insulated unit.

Edge lengths:

- Up to 1000 mm: h = 18 mm
- over 1000 mm to 3500 mm: h = 18 mm
- over 3500 mm: h = 20 mm

With edge lengths up to 500 mm, the height can be reduced for a small glazing bar with the rebate being 14 mm and the glass inset reduced to 11 mm. The glass inset should be about 2/3 of „h“, but must not be more than 20 mm. This also applies to sloped glazing in order to avoid to large a shadow (particularly in cold areas).

Minimum thickness of glazing tape v_d for level glass units is to be in accordance with ÖNORM B 3722 01/1999 and the following tables.

General Glazing Guidelines

Monolithic glass

Type of glazing	Frame material		
	Wood	Plastic	Metal
Monolithic glass	3 mm	4 mm	4 mm

Insulating glass

Longest side of the glazing unit cm	Frame material				
	Wood	Plastic		Metal	
		light	dark	light	dark
	v_d ¹⁾ in mm				
- 150	3	4	4	3	3
150 – 200	3	5	5	4	4
200 – 250	4	5	6	4	5
250 – 275	4	-	-	5	5
275 – 300	4	-	-	5	-
300 – 400	5	-	-	-	-

¹⁾ The thickness of the inner glazing tape can be up to 1 mm smaller.
Values not given should be obtained from the sealant manufacturer.

General Glazing Guidelines

Use of sealants

Should different materials come into contact with each other during installation, it is possible that chemical or physical reactions may occur.

Recognised test methods which describe material behaviour when in direct contact with each other, with materials from insulating glass edge seals and contact with the edge of laminates are given in the ift Guidelines DI-01/1 and DI-02/1.

Austrian standard ÖNORM B 3722 defines the compatibility of the reactions between many chemical materials without negative alterations. It is the responsibility of the user to check the compatibility of different materials in their application.

Glazing block guidelines

Glazing blocks have the role of fixing the location of the glass unit in the frame so that load transfer occurs over the anchor points or junctions of the fixed frame or over the suspension points of an opening vent (see also ÖNORM B 2227 Clause 5.3.3.3).

The following must be assured:

- that the frame and casement do not twist, lose square, or catch edges, and that the clean movement of the casement is assured
- that the glass does not touch the frame or construction parts such as screws, at any location, and that the clearance between rebate base and glass edge remains uniform
- that the glass unit does not incur any load transfer from the frame (see Technical Guideline Nr. 3 of the Institute of Glaziers for glazing techniques and window construction).

Role of glazing blocks

Glazing blocks required for glazing differentiate themselves dependent on their role in:

T = Setting block: these support the glass in the frame

D = Distance blocks: these provide the space between glass edge and frame

Distance blocks can, in certain opening types, also perform as setting blocks.

The blocks should, depending on weight and load capacity of the

General Glazing Guidelines

rebate base, be 80 – 100 mm long. They should be 2 mm wider than the thickness of the glass unit (ÖNORM B 2227 Clause 5.3.3.3). The thickness depends on the rebate clearance but at insulating glass must be a minimum of 5 mm. In particular it is important to take account of tolerances (see ECKELT Handbook Tolerances).

Material of glazing blocks

The material used for the blocks, their colouration, impregnation (of wooden blocks) and their composition must be in accordance with ÖNORM B 3724 Clause 5.4 and ÖNORM B 2227 Clause 5.2.4 and ÖNORM EN ISO 1160 „Classification and requirements for sealants in construction“ and be compatible with the materials of the insulated glass edge seal, with the sealants and PvB interlayers of laminated glass (ift-guideline DI-01/1 and DI-02-1). The blocks must have sufficient resilience and must not change their characteristics through contact with the sealants and adhesives; through moisture or other environmental influences as well as the weight of the units. Blocks which are held in place with sealant etc. must be checked for compatibility with that material. Self-fixing blocks can be used.

Hardwood blocks (e.g. Oak or Beech) with faultless impregnation (to resist against moisture and mould) are preferred to other types of wood whose resilience is less known. Other materials e.g. plastic, should only be used when the manufacturer has confirmed their suitability in writing.

General Glazing Guidelines

Heavy units

Heavy units such as those more than 100 kg, should use blocks made from Polyamide, Chloroprene, APTK, PE or Silicone profile (not PVC) with a minimum thickness of 5 mm and a Shore-A-Hardness of 60 – 70 degrees. To accommodate unevenness in the rebate, a level and capable support must be achieved.

Location of blocks, bridges

The blocks must be secured against slipping in the frame rebate (see also ÖNORM B 2227 Clause 5.3.3.3). The distance of the block from the corner of the glass unit should typically be the same as the minimum block length. Should the blocks close drainage channels, hinder electronic cables used for alarms, louvre operation or heating (horizontal and vertical), then suitable block bridges with a lengthwise slot of 8 x 4 mm should be used. The blocks require a level and stable support surface; grooves or unevenness in the rebate base are stable to bridge across.

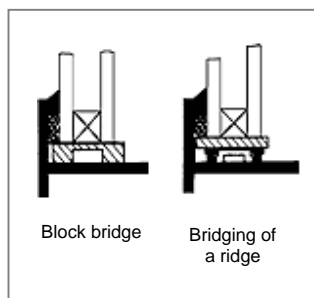

General Glazing Guidelines

Should the frame manufacturer have specific blocking guidelines, then these need to be checked by us for suitability. This also applies to blocking of insulated units in potentially unstable frames to prevent deflection of the casement. The lowest allowable distance from the corner of the unit is 20 mm, otherwise glass breakage is a risk.

Blocking mistakes

These schematic diagrams show blocking mistakes. They can lead to glass breakage or damage of the edge seal.

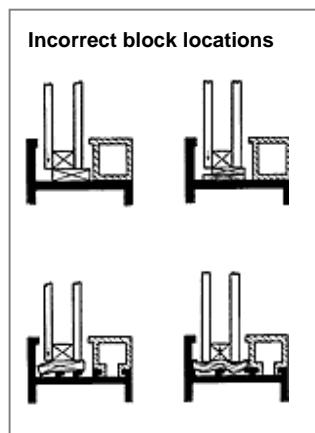

General Glazing Guidelines

Flat glass sheets

Example of casement types (blocking recommendations)

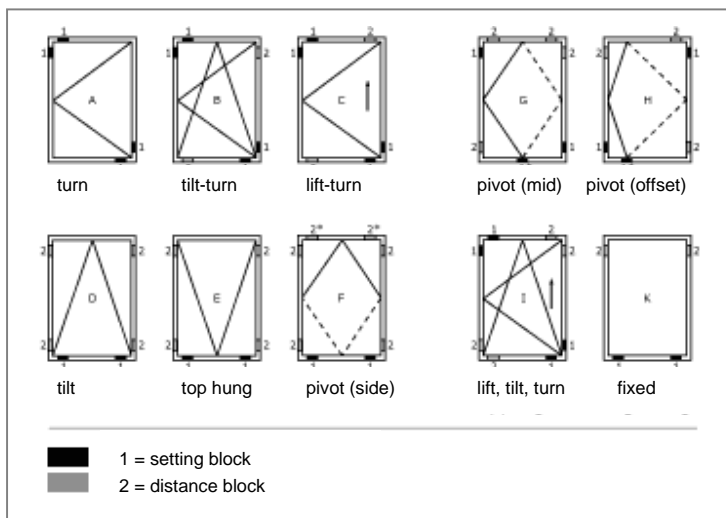

1 * units wider than 1 m should have 2 setting blocks of at least 10 cm length over the pivot point

2 * are setting blocks in horizontal pivot windows

Blocking of windows with muntin bars

In windows with muntin bars, it is necessary to block each field in accordance with the type of opening.

Blocking of sloped glazing

Sloped glazing is to be treated like „fixed glazing“, particularly with regard to distance blocks.

In addition it is necessary to use a lower setting block which is

General Glazing Guidelines

parallel to the glass edge in order that all sheets of the unit and their loads are carried.

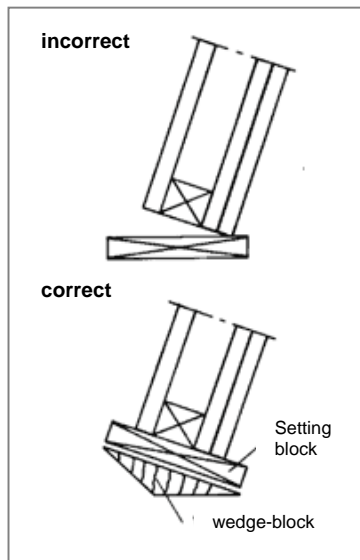

Shaped units

The load-carrying of „stood-on-head shaped units“ must also be accommodated with setting blocks. However, to avoid stress, the block should be harder to withstand the increased load. With symmetrical locations, the block also needs to be harder.

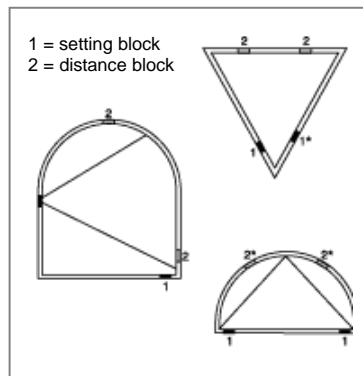

General Glazing Guidelines

Bent glass

Bent monolithic or insulated units must also have setting blocks the same as flat units.

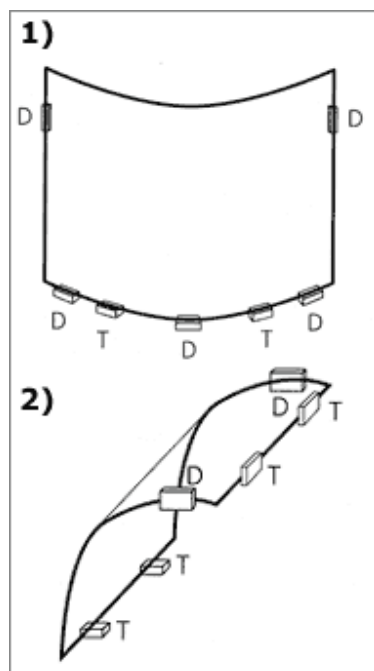

T = Setting block of silicone or APTK/EPDM 60° - 70° Shore. Additional block to avoid tipping

D = Also silicone or APTK/EPDM 60° Shore. Weight sits only on the setting blocks

With type 1) the glass weight is taken by the lower bent edge and load is transferred into the frame (and eventual support structure) via the setting blocks (vertical distribution).

With type 2) the glass weight as well as the wind load is taken by the lower glass edge, but also by the glass edges. For this reason, it is necessary to use a support profile which accommodates the tolerances of the bend (to be checked with the manufacturer) and simultaneously allows load transfer and provides a seal. Silicone profiles (60° - 80° Shore with no

General Glazing Guidelines

glazing tape) offer a good possibility for support and provide a seal and can be used in lieu of the upper setting blocks.

For the edges which are „not loaded“, a glazing tape and sealant system should be used. Silicone profiles provide the ability to achieve an efficient bond and seal when used with a suitable silicone.

General Glazing Guidelines

Glazing systems

The glazing systems shown are only indicative. Whether they apply to a particular installation of insulated units and the required methods can only be determined by the system manufacturer or glazier.

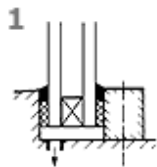

1 Elastic sealing weather- and room-side with closed-cell glazing tape/rod.

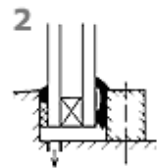

2 Closed cell glazing tape/rod with elastic sealing weather-side and a roll-in / slide-in gasket room-side

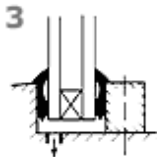

3 Profile glazing with roll-in or slide-in gaskets, which are pressured by the frame self-pressure.

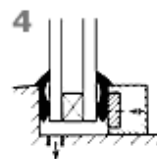

4 Profile glazing with controllable pressure elements

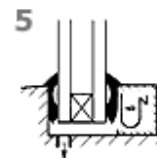

5 Profile glazing with self-pressurising elements (springs etc..)

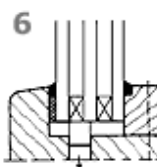

6 Glazing of wood windows without glazing tape. In accordance with the „Guideline for glazing of wood windows without glazing tape, Point. 2.1“ from 9/83 Institut für Fenstertechnik, Rosenheim, the inner glazing tape can be omitted when a suitable groove in the glazing bar for internal sealing is provided and a distance of at least 0,5 mm to the glass is achieved.

General Glazing Guidelines

Glazing with one-sided tape

This type of glazing is not suitable for performance glass types such as solar control, acoustic control, increased thermal insulation and increased safety.

It is important that the outer glazing tape does not cause the glass to be clamped in the rebate and that no local over-stressing occurs.

The specification of glazing in wood windows from Institut für Fenstertechnik, Rosenheim, does not allow glazing tape but determines that a gap between glazing bar and glass is necessary.

The method of glazing should be chosen from ÖNORM B 3724.

Glazing without glazing tape

Glazing without glazing tape on both sides is not recommended as a general method for glazing.

Should this method be chosen for an individual case, then it is strictly necessary to follow the determined tolerances as given in the guideline for wood windows without glazing tape, ift Rosenheim 09/83. Otherwise it is possible that unwanted forces occur which may result in breakage of the insulated unit.

 General Glazing Guidelines*Glazing tape – Rebate base*

It is recommended that at least 5 mm clearance is kept between the bottom edge of the glazing tape and rebate base, to ensure that no moisture traps occur.

Sloped glazing

Generally systems 1, 2 and 6 from page 18 are not possible with sloped glazing. With 1 and 2, the glazing tape is used as a load-bearing „profile system“. Such a method requires a special tape which is suitable for this kind of application.

Use of gaskets

Gaskets must be suitable for the type of window system. They must be permanently impervious in the corners and at joints on the weather side. They must accommodate thickness tolerances of the insulated units without compromising on their sealing capacity. The choice of gasket system should be in accordance with recommendation of the material supplier and frame manufacturer.

The gaskets can be made of Chloroprene, APTK, (EPDM) or silicone. Depending on the material, they should be vulcanized or bonded (to manufacturer's recommendations) in the corners on the weather-side or both sides (in high humidity or climate-controlled rooms).

 General Glazing Guidelines**Pressure**

For screw-held pressure plate systems, it is necessary for the system manufacturer to determine the correct torque from the location of the screws (to each other or from end of profile) and the type of screw. It must be ensured that the pressure plate provides a uniform surface pressure on the glass edge to a maximum of 20 N/cm-run of edge length. This is particularly applicable to sloped glazing and corners.

This also applies to profile glazing. Too much pressure will cause loss of tightness in the seal of the insulated glass. The correct pressure for the glazing bars are to be determined by the manufacturer. A typical value is 15 N/cm-run of edge length.

Vertical installation

General glazing technology Aluminium, plastic

Current technical knowledge for metal and plastic frames requires a clear rebate to ensure their function. To ensure that the external climate is dominant in the clear rebate, a sufficient pressure equalization is necessary. The openings used to achieve this should also allow for drainage at the lowest point of the frame construction.

The frame construction should facilitate a seal which acts as a moisture barrier to the inside.

To ensure this function, all glazing methods must permanently guarantee a faultless seal of the rebates under all prevailing conditions.

Generally applicable:

The frame construction must be sealed, above all at the joints and connections of the profiles.

A defining part of this guideline is the table „Qualification groups for glazing of windows as well as explanations from the Institut für Fenstertechnik in Rosenheim“.

A completely sealant-filled rebate, even if possible, will always lead to moisture traps, even on flat bonding surfaces. From there, the aggressive destruction of the sealant and therefore the edge seal of the insulated unit begin. Should an area not

General Glazing Guidelines

bond correctly, it is possible that a micro-climate occurs which leads to destruction of the edge seal system. The life-expectancy of the unit is thereby significantly reduced. With laminated glass, moisture pockets will lead to alterations in the interlayer.

Composite constructions

Composite constructions Alu-Wood or plastic-wood are to be treated in the same way as metal or plastic windows, namely with pressure equalization openings.

Wood windows

Wood windows require glazing with a sealant-free rebate.

Wood windows with a grooved rebate base suffice when the groove carries outward from the middle seal. The groove should be approximately 8 x 5 mm.

Location of pressure equalization openings

The openings to the glass rebate for pressure equalization must be outward and in front of the middle seal.

With openings toward inside, moisture load on the rebate and therefore the edge seal is increased and will reduce the life-expectancy of the insulated unit.

This type of glazing is not acceptable.

 General Glazing Guidelines**Ventilation of the rebate**

Room-side ventilation of the rebate can (e.g. when there is no wind) lead to long-term deposit of moisture from the room into the rebate which can lead to condensation when cooled.

This causes an extreme chemical load on the edge seal of the insulated unit and is contrary to general knowledge about the „pressure equalization to outside air“ (see also Clause „Pressure equalization “).

Repair glazing of windows

The aging behaviour of insulated units in replacement glazing must not be underestimated. The existing glazing system can be re-used with confidence if the failure to the unit is proven to have come from an external mechanical source (stone etc.) However, if it is the glazing system which has caused failure, then the warranty is void. (see also Clause general glazing techniques.) Should fogging be apparent in the cavity then the use of the glazing system needs to be evaluated in accordance with current standards.

Pressure equalization

Pressure equalization systems must be able to guarantee timely disposal of any condensation in the rebate to outside. They must also allow pressure equalization through air circulation and facilitate a reduction in excessive moisture.

General Glazing Guidelines

Pressure equalization for gasket systems with clear rebates is sufficient when the following criteria are fulfilled as a minimum, and for each glazed field:

- It must be ensured through suitable methods that pressure equalization does not occur to the inside (e.g. behind the middle seal or via unsealed glazing bars or construction joints), otherwise it is likely that high amounts of condensation will occur – above all in room with high humidity.
- The pressure equalization openings must be located at the lowest point of the glass rebate. The openings should be smoothed. Profile residue from cutting the openings and ridges must be cleared.
- Setting blocks must not hinder any potential water flow or the pressure equalization (minimum block thickness is 5 mm). Grooves and unevenness in the rebate are stable to be bridged by the setting blocks. Flat rebate bases require block-bridging.
- The openings for pressure equalization must not subject the rebate to direct wind pressure from the outside. In multi-chamber systems this can be accommodated in the outer chamber. This chamber then acts as pressure equalization.
- Should such openings e.g. in fixed glazing frames, „stick“ profiles or steel profiles, face direct from the rebate horizontally outwards, then the openings should be protected with a suitable cover which has a sufficient fall and which typically stops any water from funneling back into the rebate.

General Glazing Guidelines

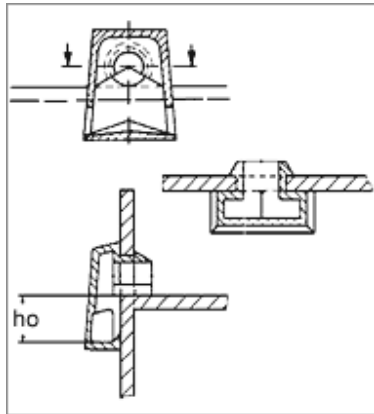

Schematic: Example of a cover plate

Additional measures

Openings in upper corners of the rebate allow a quicker equalization of humidity. Under normal conditions these measures can be seen as an additional improvement to the life-expectancy of the unit. This is particularly applicable to room with high permanent humidity (see also next clause).

With thermally insulated metal profiles, we recommend that the openings are located in front and outward of the thermal break.

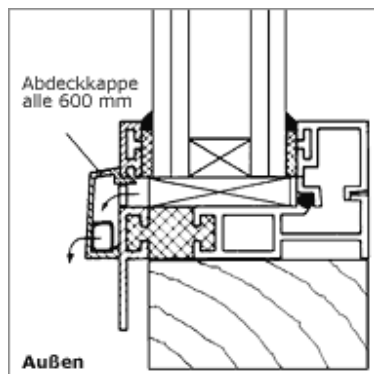

Cover plate every 600mm
Outside

Schematic: Pressure equalisation in fixed windows

General Glazing Guidelines

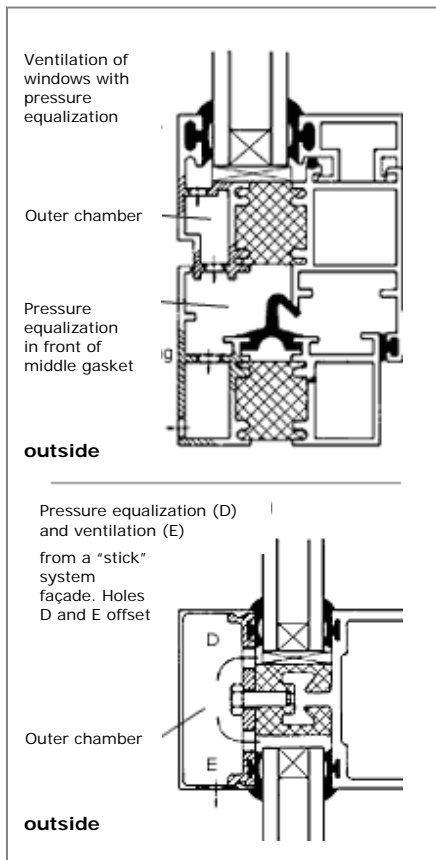

Schematic: Pressure equalization as described

General Glazing Guidelines

Rooms with high humidity

These are rooms such as Swimming pools and climate controlled rooms with humidifiers. Because of the high moisture pressure and additional chemical influences, the seal system in such glazing and frame constructions should be positioned inwards. Depending on the actual system, there are differing seal possibilities which could be films, profiled gaskets or sealants.

Should the glazing bars be applied from outside then it is obvious that the complete construction should be suitable for such an application. Simply reversing the facade / window elements is not a technically sound solution.

If room-side glazing bars are necessary, then it must be ensured that particular measures are taken to seal the joints and support surfaces. In addition, pressure equalization openings in the upper part of the frame are needed.

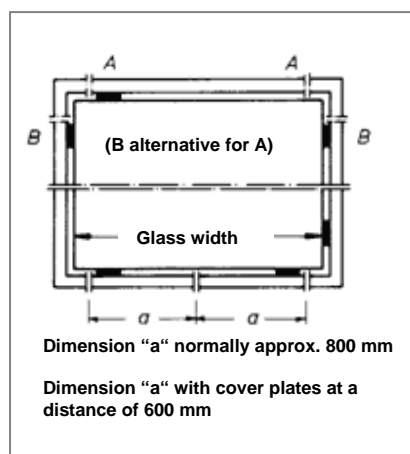

General Glazing Guidelines

Glazing systems with wet-applied sealants should be as per exposure group Vf5 in the „Rosenheim Tables“. Sealant depth should be increased by at least 1mm.

In addition, the Technical Guidelines 16 + 17 of the Glazier trade (Hadamar) also apply, insofar as they do not contravene this guideline.

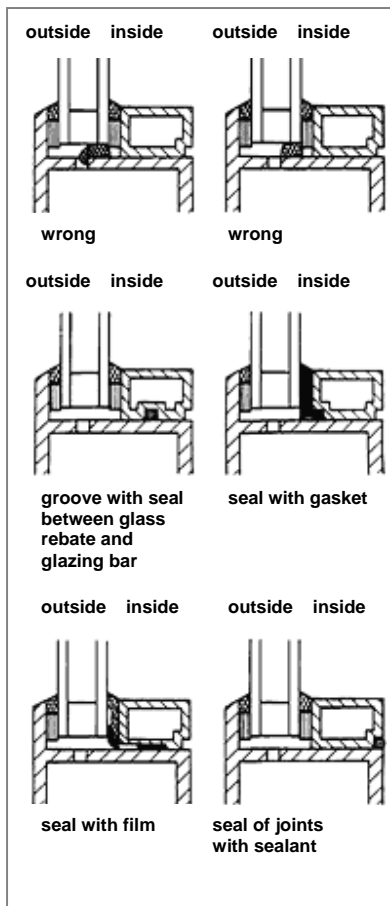

Principle for inner-sealing of rebate for exceptional situations

 General Glazing Guidelines

Note

Uncontrolled application of sealant depth can lead to hindrance of pressure equalization and cause moisture pockets.

Sloped installation

In comparison to vertical glazing, conditions are different for sloped glazing. Depending on the angle of slope, the period of sunlight incidence will vary. At night, there is an increased cooling effect from energy radiance. This creates significantly higher temperature differences for the glass and frame.

Rebate

A sealant-free rebate is generally required. Condensation and water that has leaked in must be disposed of to the outside.

Support profile

With sloped glazing, the lower support profile serves as load-bearing (self-weight, Wind load, Snow load). For this reason, glazing tape cannot be used. A suitably dimensioned support strip or profile must be used which can accommodate the loads.

External cover plates

Cover plates are used to hold the glass in place but they must not induce any stresses.

Seal surface

The water disposal surface and the seal position (to inside) must be separated from one another (see also glass inset).

General Glazing Guidelines

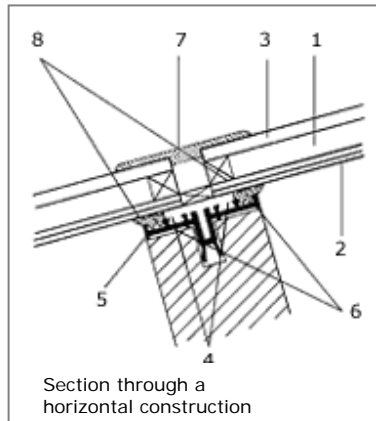

1. Cavity
2. Inner glass, overhead glazing with STADIP
3. Outer glass
4. rebate, water-disposal surface
5. Glazing block (Distance block)
6. Inner gasket, support profile with 70° - 80° Shore (Silicone profile) slightly profiled no foam strip!
7. Gasket of silicone (Sipro 60° - 70° Shore)
8. Seal surface

Seal surface 8 separated from moisture control surface (rebate base) 4.

Cover sheet / Warm bridges

Externally applied large area metal constructions at the edge of the glass act like cooling-ribs and can, as a result of temperatures, also influence the inner frame and glass edge. These can lead to short-term condensation (Warm bridges see also EN ISO 10211-2). This externally influenced occurrence can not be seen as a defect of the glass unit. Warm bridges of this type increasingly occur on contemporary, highly insulated materials, but can be reduced through constructive measures.

Self-radiation by the outer sheet

The increased self-radiation of the outer sheet to the night sky in sloped glazing as well as thermally enhanced glass e.g. CLIMAPLUS, leads to increased cooling of the outer glass. Short-term condensation build-up on the outer glass surface at high humidity in the outside air indicates the good thermal insulation

 General Glazing Guidelines

performance of the glass unit.

Glass types

Composite constructions Alu-wood or plastic-wood are to be handled the same as metal and plastic windows with pressure equalization openings.

Outer sheet

The outer sheet can be made of normal Float glass PLANILUX. Should increased breaking strength (for hail impact) and/or temperature change resistance (casting shadows) be desired or necessary, SECURIT or PLANIDUR can be used.

Inner sheet or monolithic glazing

The inner sheet of glazing or monolithic glazing in sloped applications such as roof slopes and shed roofs etc. must be splinter-free. We recommend the use of STADIP laminated safety glass in accordance with ÖNORM B 3716-2). We recommend applying this directive even in private dwellings.

The use of wired glass or polished wired glass must consider information released by authorities such as the Federal Ministry for Economics and Employment to the Employment inspectorate for the 1st to 19th districts. (see reference: 461.204/1-III/2/04).

 General Glazing Guidelines**Glass thickness**

Glass thickness calculations can be made in accordance with ÖNORM B 3716-2. Regional specifics, amendments or restrictions must be considered.

Cavity

The cavity will e.g. through the sun's rays on the adjacent glass, become warmer and in the night colder (see *Self-radiation by the outer sheet*) than in vertical glazing. It is therefore recommended that the cavity is restricted to a maximum of 15 mm to avoid glass breakage.

Glass inset

The inset of the glass should generally be in accordance with ÖNORM B 3722 and not larger, in order to avoid temperature differences between the edge and glass surface. Individual constructive measures such as location of thermal insulation of the frame, area proportion of outside to inside can be of influence here.

The glazing bars in roof glazing are generally to be placed on the outside, as inner-laying sloped bars act as the water-disposal surface and make sealing practically impossible.

The water disposing surface and the seal surface must be faultlessly separated. The water disposal surface should lay lower. The outer glazing bars must protect the glass unit from being ripped out under negative wind loads (ÖNORM B 1991-1-4) and are to be sized and fixed as such.

General Glazing Guidelines

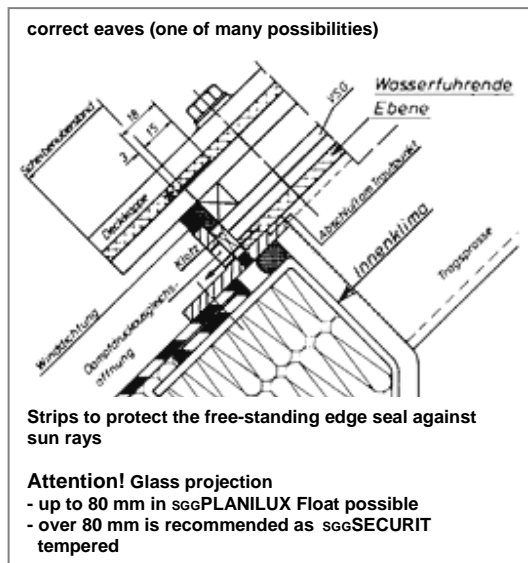
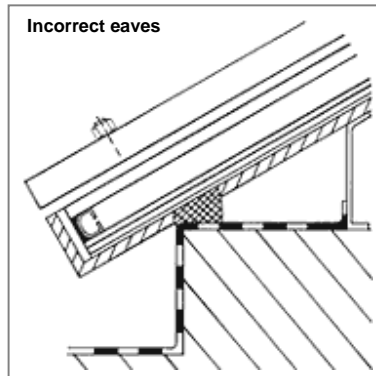

Angle of slope

Roof pitches less than 10 degrees are not recommended. This recommendation comes from general knowledge from flat roof technology. Water should be able to run away freely. This is applicable to not only to the glass but also to the frame construction. Other external factors such as soiling and leaves

General Glazing Guidelines

should be considered. Long-term moisture (ponding) can cause surface damage to the glass.

Heat build-up

It is important to note that heat build-up behind the glass or uneven heating-up of the glass surfaces is to be avoided. The free glass surface must be allowed to be uniformly enveloped by the room-side climate. In addition, multi-pane insulated glass units must not be laid across the whole length of the wall below the eaves. The glass must also not have its free-standing edge acting as the eaves. A stepped edge unit should be used. Overlapping of normal insulated glass elements is not permitted. Should glare protection be used internally, then a sufficient distance to the inner face of the glass is required (approx. 20 – 30 cm). It is possible in Europe that the sun's rays can raise the temperature up to 60°. Cooling at the edge or other thermal changes can lead to glass breakage. For a practical application, this means that constructions are to be chosen which allow a uniform heating-up of the glass surface. Partial shading must be avoided.

Stepped edges

Stepped edge units with projecting outer sheets are offered to assist the designer to find a solution with regards to the points „angle of pitch“ and „heat build-up“.

The projecting sheet can be located over the carrier profile and wall. At joints, the upper sheet can be overlapped. This ensures

General Glazing Guidelines

a suitable flow of water. In such cases the glass should be SECURIT tempered.

At overlapping joints at insulated glass, the upper edge seal needs to protect the lower glass sheet or be constructed using UV-resistant sealant (see next point). The glass thickness at the overlap must be exactly leveled in the construction. The projecting glass sheet must not be allowed to touch anything nor act as a support for the unit.

Edge cover

The standard edge seal used in multi-pane insulated units must not be subject to the sun's rays. The free-standing edge seal of the stepped unit or overlap must be protected against such.

The protection of the edge seal system can also be constructively solved by using cover-plates, profiles, adhesive silicone tapes or with screen-print.

Joints between roof units of insulated glass can also be installed flat. The horizontal edge seal of both units must be protected at this joint by e.g. cover-plates, profiles, adhesive silicone tapes or with screen-print on the outer sheet.

Glass rebate

Metal contact in the rebate (e.g. base, support angles etc.) is not permitted, as is direct contact between the glass unit and the frame. Glass to metal contact must be permanently avoided by using distance blocks etc.

General Glazing Guidelines

Setting blocks must not hinder pressure equalization or drainage. The glass unit must sit perpendicular on the block in order to avoid edge damage and subsequent breakage.

The same guidelines apply to sloped glazing as does for vertical glazing, with consideration of the additional and differing conditions. It is important to pay attention to the fact that glazing tapes are not suitable to support the self-weight of the glass and snow load as they will compress. Gaskets should be used which can permanently accommodate these mechanical and thermal loads.

System appearance

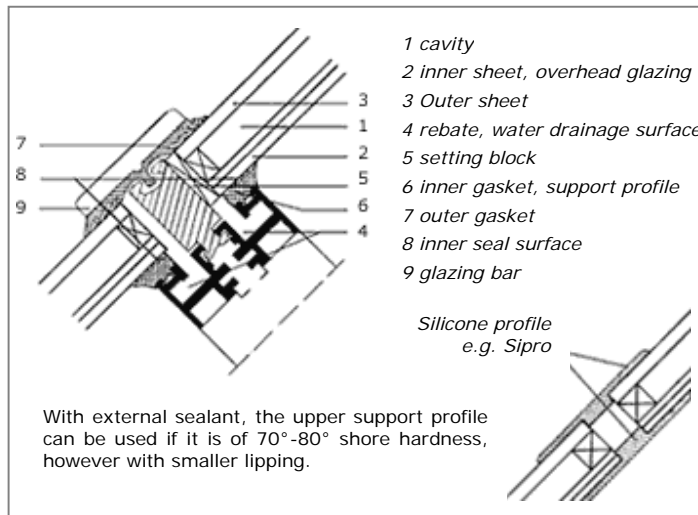

Schematic: Pressure glazing with gasket e.g. Sipro 60° - 70° Shore

The use of silicone profiles, when used with suitable silicone, can provide a good bond to glass and therefore also achieve a seal.

Performance glass: additional requirements

Glass units with additional performance functions necessitate additional requirements of the glazing or other conditions which are based on their composition and gas filling. They can e.g. heat-up more, the individual sheets can be loaded differently or the glass weight is increased.

This is particularly applicable for:

- Person and splinter protection
- SECURIT ALARM
- Thermal insulation
- Acoustic insulation
- Solar control

The guidelines for regular glazing apply, but the following additional points must be considered.

IGUs with Solar control glass

Insulated glass units with solar control glass (absorbing as well as reflecting) should have the inner sheet as SECURIT because of the heat build-up and the resulting increase in pressure in the cavity.

Acoustic control

Insulated glass units with enhanced acoustic characteristics typically have asymmetrical sheet thicknesses and wider cavities. Temperature increase and barometric pressure variations result in additional loads which can cause problems

General Glazing Guidelines

with small units and units at high elevations above sea level. It may be required that the thinner sheet be made of SECURIT or PLANIDUR (with cavities ≥ 16 mm).

Even for acoustic reasons, the sealant-free rebate must be complied with. Frame material and form, glazing systems and glass unit sizes have an influence on the acoustic performance of the whole window element. Values may deviate from test results in accordance with EN ISO 717-1. A glazing system without sealant reduces the acoustic performance of the window.

Should functions other than acoustic protection be needed e.g. g-value, structural requirements, Safety requirements or also optical aspects, then it may be necessary to deviate from the tested composition. Consultation is necessary.

Asymmetrical glass compositions normally have the thicker sheet on the outside. ÖNORM B 8115-4 Point 5.3.4 gives information about the application and classification of glass and acoustic protection windows. Installation type, dimensions and additional roller-blind systems as well as continuous window sills need to be considered in the evaluation of acoustic performance.

Thermal insulation

Thermal insulation glass has a lower energy loss in comparison to normal insulated units. The lower rate of energy loss in modern thermal glass types, determined by the temperature difference between the outer and inner sheets is greater than in standard insulated units ($U_g = 3,0 \text{ w/m}^2\text{.K}$). As a result, it is

General Glazing Guidelines

possible that higher thermally induced stresses occur in the cross-section and at the edge, which must be considered in different glazing systems and applications. This particularly applies to applications of suitable installation and with combination using solar control glass.

Where glass thickness difference is ≥ 3 mm it is possible that the thinner sheet may break, dependent on its size and the heat build-up in the cavity. A suitable calculation is therefore recommended.

In any case, the glass should be made of SECURIT tempered. This applies particularly for glass with a size of approx. 400 x 700 mm. It is important to note that heat build-up behind the glass or uneven heating-up of the glass surfaces is to be avoided. The free glass surface must be allowed to be uniformly enveloped by the room-side climate. Partial shading must be avoided. Should an inner shading device be used, it is necessary to provide sufficient distance to allow ventilation between the shading device and the glass.

Solar control glass

Solar control glass types typically heat up more in the sun's rays than normal insulated units. This also applies to the cavity which „pumps“ harder. Such additional stresses can lead to glass breakage. Particular danger occurs to glass which has shading that causes high temperature differences. Thermally tempered SECURIT and PLANIDUR glass types reduce this risk of breakage. Cavities larger than 15 mm should be avoided. This

General Glazing Guidelines

applies e.g. for units of approximate size 400 x 700 mm.

The glass thickness of the individual sheets should be the same if possible but should not differ by more than 2 mm.

Sliding doors

In sliding doors, the opened glass units stand behind each other. Sun rays lead to a heat build-up between the units which can lead to failure. Solar control or thermally insulated units can increase this influence. Suitable ventilation between the units is a necessity.

Determination of glass thickness: structural basics

In the preceding information, only the general basics and minimal requirements have been given. Building location, size, type and use have significant influences on the requirements. This applies not only to the glass but more so for the structural parts of the building which provide safety. These loads can be provided by the architect, owner or structural engineer. The glass manufacturer or processor requires detailed information to determine a correct and suitable glass thickness for the specific project.

Should technical regulations be missing, then it is necessary to obtain or establish this information from the governing authority or other responsible parties so as to determine the basis for calculation, glass type and details of their requirements.

Loads

ÖNORM B 1991-1-4 Actions on structures - general and wind actions – lays out the different application cases, building shape and building element requirements. EN 1991-1-3 Effects on support structures – general effects of snow loads - classifies national snow loads. The worst case scenario is to be used from a combination of wind load, snow load, self-weight and service load as well as climate load.

Additional notes

External conditions have a strong influence on the life-expectancy of the glazing. For this reason, some of these cases are noted here. They are based on the information in this guideline but should serve as explanation to the professional in order to assess the project specific situation.

Storage

It must be ensured that packed units of glazings are generally stored standing vertically. Incorrect storage (even short-term incorrect) can cause twisting of the crate which may lead to glass breakage. Storage areas must be dry.

On construction sites, it is also necessary to store especially insulated units when possible inside the building in their crates or on A-frames. Loose insulated units may be stood for short periods of time on wedge-shaped supports with cushioning of hard foam or similar.

 General Glazing Guidelines**Thermal loads***Radiators*

Radiators should be at a distance of at least 30 cm from the glazing to avoid unallowable stresses in the glass. At close distances a radiation shield may be used. Should the sheet of the insulated glass facing the radiator be of SECURIT tempered safety glass then the distance can be reduced to 15 cm.

Asphalting

Insulated glass must be protected from temperatures expected when asphalting in glazed rooms.

Should solar energy be expected from outside, then an external sun protection should be used to avoid heat build-up.

Glass which has been painted or has stickers

Insulated glass which has been painted or covered with stickers, it is possible from the localised temperature difference or heat build-up that the glass may break.

Storage / Transport

Storage and transport of stacked units in the sun, with or without packing, can be expected to have thermal breakage, particularly when solar control or thermal insulation coatings have been used.

 General Glazing Guidelines*Sliding windows / doors*

In sliding doors, it is possible that the opened single pane or glass units will stand behind each other. Insulated glass with solar control or thermal insulation has a potential for heat build-up between the units. Suitable ventilation between the units is a necessity to avoid partial heat pockets. The use of SECURIT can help this problem.

Surface damage

Many factors can lead to damage of glass surfaces. Protective measures should be taken dependant on the local conditions.

Welding / Grinding works

Welding or grinding works close to the glass require effective protection to avoid weld-splatter and sparks which may indent the surface.

Etching / corrosion

Surface etching of the glass can be caused by chemicals which are inherent in a great number of building materials and cleaning agents. In particular, long-term contact of such chemicals (alkalis, acidic solutions) can result in permanent etching. This also applies to fresh concrete, plaster, render etc. if they come into contact with the glass surface.

General Glazing Guidelines

Cleaning

Glass must be cleaned regularly including during the construction phase, as heavy soiling in combination with water can cause etching and staining (see general cleaning recommendations).

Scratches

Glass sheets must not be cleaned or worked with abrasive materials. Cleaning water as well as sponges, cloths etc. must be free of granular materials such as sand. Heavily soiled units must be cleaned using lots of water. The cleaning of facades and therefore the glass should be carried out in accordance with „Cleaning of metal facades, RAL-GZ 632“.

Cleaning of glass surfaces with „glass planes“ or razor blades etc. is not permitted.

Note:

Every insulated unit must, before installation, be checked for damage of any kind. Damaged units must not be installed. Multi-pane insulated units are to be handled so as not to induce any torsion.

 General Glazing Guidelines**Installation at extreme elevations**

Insulated units are hermetically sealed at the prevailing barometric air pressure in the production facility i.e. the air pressure in the cavity will be the same as the barometric air pressure at the time of sealing (see double-sheet effect). It is possible that external conditions (temperature, air pressure) may cause additional stresses in the glass which when combined with wind load can lead to breakage. Calculations can determine limits of units in this situation.

It is unusual that the manufacturer will know the exact geographical elevation of the installed units. It is therefore necessary to advise at time of order when the height above sea level is greater than 800 m.

With insulated units from the product ranges CLIMALIT ACOUSTIC, CLIMAPLUS ACOUSTIC, in combination with COOL-LITE K, PARSOL and ANTELIO as well as large cavities, we recommend consultation with our staff.

Other factors*Aspect ratio*

Insulated units with an edge length under 60 cm and an aspect ratio (width to height) greater than 3:1 have an increased risk of breakage. Consultation with our staff is recommended. In any case we recommend the use of SECURIT.

 General Glazing Guidelines*Concave / convex „bellying“*

As a result of the hermetically sealed cavity space, concave or convex „bellying“ of the unit may occur as a result of pressure differences (barometric changes in air pressure, temperature changes and installation elevation).

Old buildings

Current technology for insulated units is greatly different to that of even a decade or so ago. Older buildings which have existing frame systems will have difficulties finding suitable replacement products to fit. Consultation with our staff is recommended.

External solar control

Externally located solar control or glare protection elements may have an effect on the type of glazing required.

Glass breakage

Glass thickness calculations depend on the strength characteristics of the particular glass type and application. Overstressing through unforeseeable loads e.g. hard/soft impact, thermally induced stresses, barometric air pressure variations or movements of the frame can result in glass breakage. Glass breakage is not grounds for any claim within the scope of our warranty.



General Glazing Guidelines

Replacement and later deliveries

Replacements or later deliveries of glass which take place after a considerable time may be subject to slight colour differences as a result of thickness and production tolerances. These conditions are production-technically defined and cannot be reason for any claim. This applies in particular to coloured, coated or patterned glass types.